

# drylin®.E...

Lubrication-free linear actuator with motor



...05.2013... plastics for longer life® ...

# igus®.eu

...www.igus.eu/eu/drylinE...

# ...electric...

## drylin® E

“E” as in Electric and is the latest development and addition to the modular drylin linear guide range. The lubricant-free linear guides guarantee clean and dirt-resistant operation. Ready-to-fit linear actuators and drive systems can be fitted with either leadscrew drives or belts. The range of accessories includes handwheels, position indicator, v-drives, couplings and much more. The drylin® E product range is complete with hybrid stepper motors, connectors, encoders, and the proven chainflex® power cables from igus®.

- Delivery time: 3-4 days
- 100% lubricant-free linear guide
- Cost-effective and online configuration possible

Lubrication-free linear guide system using polymer bearings

liners made of maintenance-free iglidur® J

tooth belt, trapezoidal or high helix thread

Ball bearings leadscrew supports

Motor flange: connection for stepper motors

Claw coupling

igus® motors

- Stepper and DC motors
- Cost-effective
- 25 versions
- High protection class or Low-Cost-design



3-4 days



[www.igus.eu/eu/drylinE](http://www.igus.eu/eu/drylinE)

# ...applications...

## drylin® E – application examples

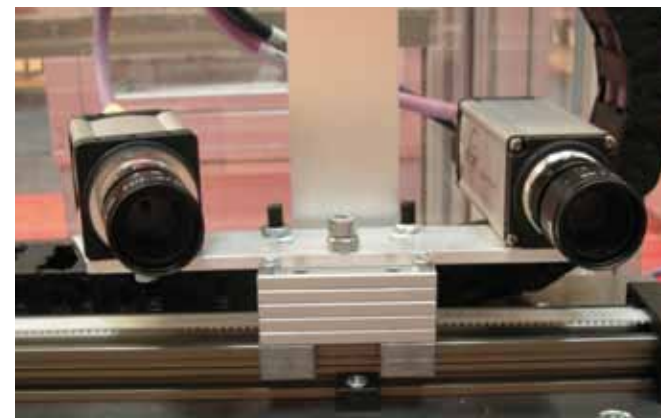

### Camera adjustment

A quiet, vibration- and lubrication-free operation is required in this camera adjustment on a conveyor belt using a drylin® ZLW toothed belt axis.



### Sampler/pipette

Space-saving telescope adjustment using a compact and lubrication-free drylin® ZLW toothed belt drives. (Sierra Sensors GmbH)



### Adjustment of inspection equipment

drylin® ZLW toothed belt drive in an inspection camera adjustment for checking the position of sealing rings. (OLPE Jena GmbH)

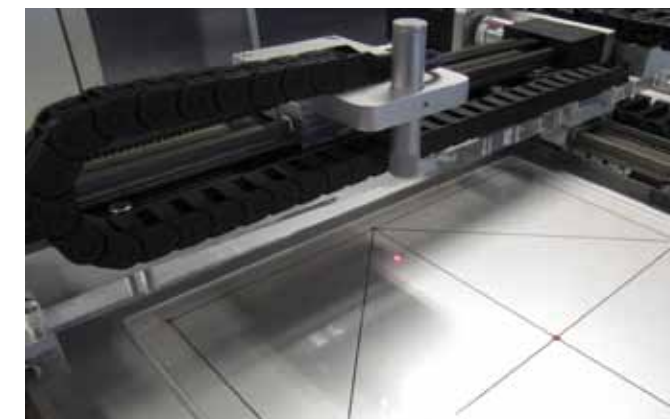

### Sensor adjustment/Measuring systems

drylin® ZLW-0630 toothed belt actuators in an X-Y configuration for adjusting a laser detector head. Compact, lightweight and maintenance-free due to polymer plain bearings.

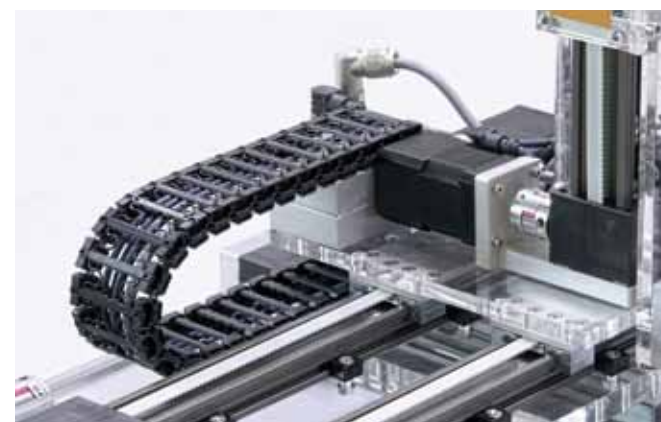

### Pick and Place

Quick and maintenance-free handling with drylin® toothed belt axes as a room portal (X, Y, Z axis).



### Handling of small parts

The tough and lubrication-free structure of the ZLW and drylin® W profiles allows a long and maintenance-free life.



[www.igus.eu/drylinE-applications](http://www.igus.eu/drylinE-applications)



# ...100% lubrication-free...

## drylin® linear technology: leadscrew and tooth belt actuators

The drylin® product portfolio provides lubricant-free linear drives that are driven either by a trapezoidal thread, high helix thread or toothed belt. The user can choose a suitable individual solution from lightweight solid plastic units up to heavy duty stainless steel solutions. In all systems, the stroke length is freely selectable and the drive implemented either via handwheel or motor.

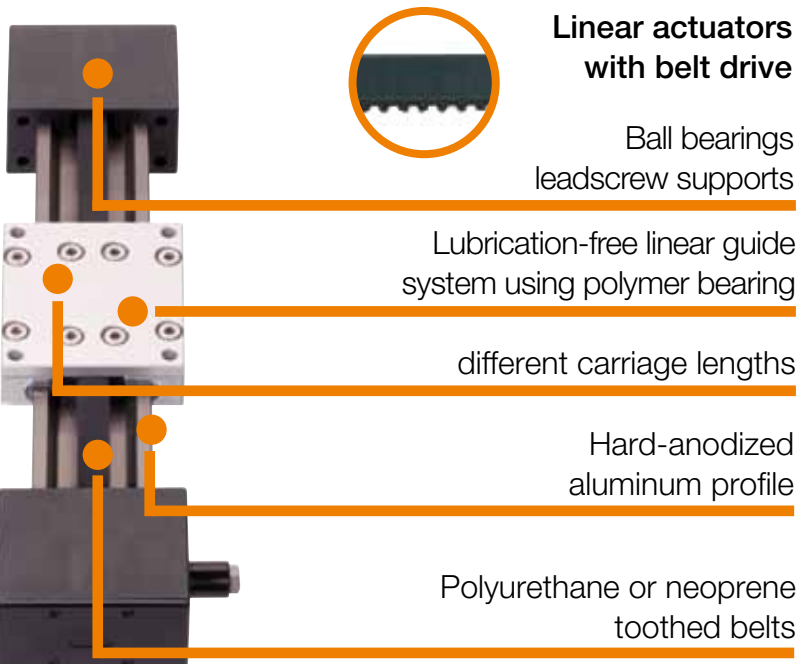

### Linear actuators with belt drive

Ball bearings leadscrew supports

Lubrication-free linear guide system using polymer bearing

different carriage lengths

Hard-anodized aluminum profile

Polyurethane or neoprene toothed belts

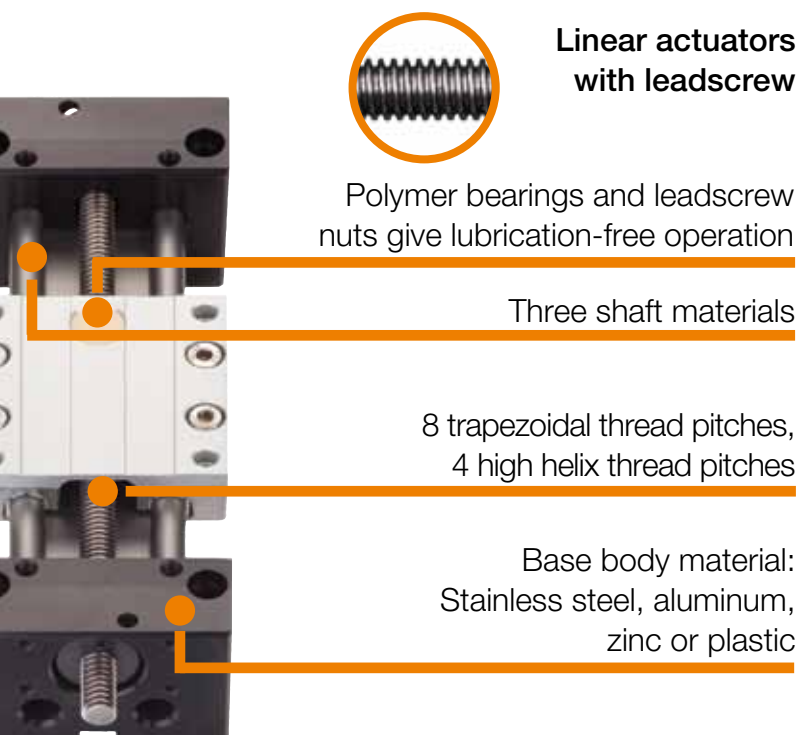

### Linear actuators with leadscrew

Polymer bearings and leadscrew nuts give lubrication-free operation

Three shaft materials

8 trapezoidal thread pitches, 4 high helix thread pitches

Base body material: Stainless steel, aluminum, zinc or plastic



#### When to use it?

- Quick positioning of small loads
- Quiet running
- Flat design
- Long-term usage



#### When not to use it?

- For high dynamic loads
- When positioning accuracy < 0.1 mm is necessary



#### When to use it?

- For format adjustments and positioning of medium loads
- In extreme environments
- When a cost-effective, ready-to-fit solution is required
- For low noise applications



#### When not to use it?

- When high loads combined with very high speeds
- When positioning accuracy < 0.1 mm is necessary
- If high running performance is required in continuous operation

## drylin® linear technology

### tooth belt drive with motor

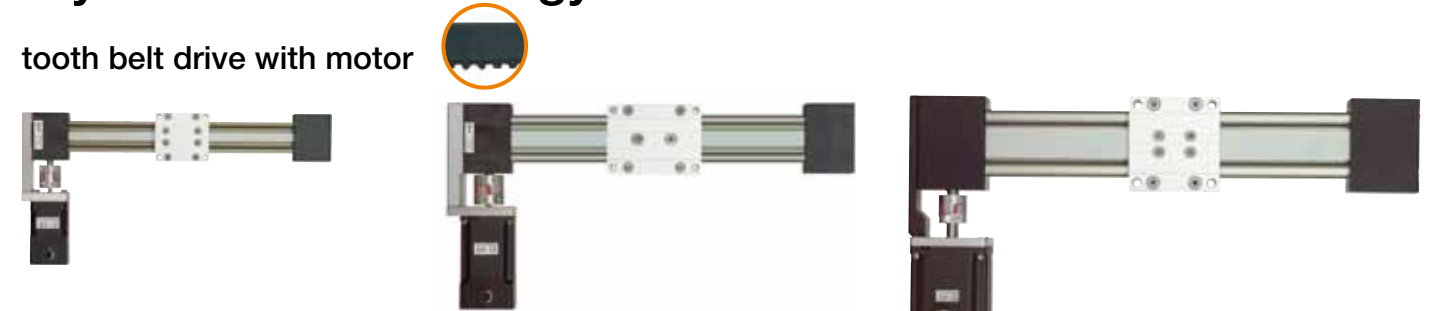

#### ZLW-0630

- Max. stroke length: 1,000 mm
- Load: max. 15 kg
- Dimensions: 54 x 31 mm

#### ZLW-1040

- Max. stroke length: 3,000 mm
- Load: max. 30 kg
- Dimensions: 74 x 45 mm

#### ZLW-1660

- Max. stroke length: 3,000 mm
- Load: max. 100 kg
- Dimensions: 104 x 72 mm



[www.igus.eu/eu/drylinE-ZLW](http://www.igus.eu/eu/drylinE-ZLW)

### Leadscrew actuators with motor

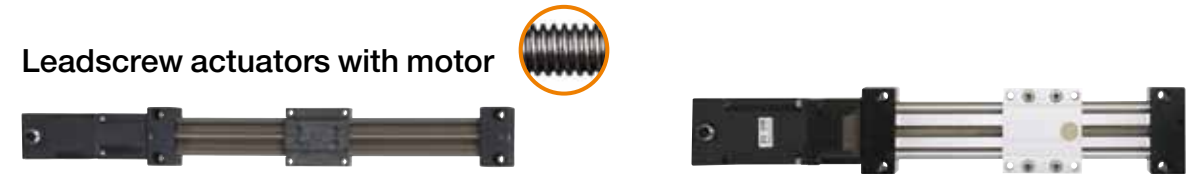

#### SAW-0630

- Max. stroke length: 300 mm
- Load: max. 40 kg
- Dimensions: 54 x 32 mm
- Leadscrew pitches: 1,5 & 15

#### SAW-1040

- Max. stroke length: 500 mm
- Load: max. 200 kg
- Dimensions: 74 x 50 mm
- Leadscrew pitches: 2, 3, 12 & 50



[www.igus.eu/eu/drylinE-SAW](http://www.igus.eu/eu/drylinE-SAW)

### Other drylin® leadscrew-linear-tables

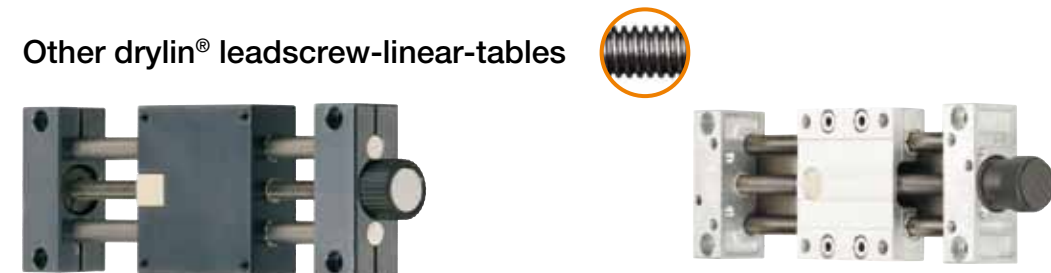

#### SHT design

- Flat design
- High precision
- Three sizes
- Optional with motor and accessories

#### SLW design

- Flat design
- High stiffness
- Five sizes
- Optional with motor and accessories



[www.igus.eu/eu/drylinSHT](http://www.igus.eu/eu/drylinSHT)



[www.igus.eu/eu/drylinSLW](http://www.igus.eu/eu/drylinSLW)

# ...with motor...

## drylin® E NEMA stepper motors: versions



### Motor with stranded wires

This motor is the least expensive and the most popular option. The connecting wires for this type come directly from the housing. They are preferably installed in machines and equipment that have an additional housing or are used in clean environments.



### Motor with connector plug and encoder

The encoder sends signals from the motor to the control unit. With the encoder the precise linear motion of the drylin® unit can be controlled. Encoder = higher reliability of the equipment.



### Motor with connector plug

Fitted with connector plug, it reaches protection class IP65 (IP: International Protection). The higher the IP protection class, the better the protection against dirt and humidity.



### Motor with plug, encoder and brake

The brake can hold the load in place when the motor is stopped. This is used as a safety feature in case of power cuts – recommended for vertically installed systems.

## drylin® E NEMA stepper motors: sizes

### NEMA17:

#### The small one with lots of power

This little motor can be impressive with good torque and high speeds. Reliable, rapid movements of smaller loads.

- The holding torque Mo is 0,5 Nm
- The mating face is 42 x 42 mm

### NEMA23XL:

#### The power motor, medium size

An advanced development of the typical NEMA23 with approximately double the torque. The mounting dimensions are the same as in the NEMA23, so that it can be used on the same mounting face.

- The holding torque Mo is 3,5 Nm
- The mating face is 60 x 60 mm

### NEMA23:

#### The most popular stepper motor size

High torque and high speed are the main advantages. This motor is the best choice for most applications in the medium load range.

- The holding torque Mo is 2,0 Nm
- The mating face is 56 x 56 mm

### NEMA34:

#### Large size, power package

Applications with high loads should use this large type. Heavy duty or parallel twin rail superstructures are typical working environment.

- The holding torque Mo is 5,9 Nm
- The mating face is 86 x 86 mm

## drylin® E accessories



### igus® motors

- Stepper and DC motors
- 25 versions
- High protection class or Low-Cost-design



### connector cables

- For motors
- Encoder, brake and connectors
- 24 versions from stock



### motor flanges

- To connect with igus® stepper motors or customized motors



### couplings

- 50 versions from stock
- Vibration-dampening and flexible



### position switches

- High protection class
- Precision fit to the linear guide rail





# ...design kit...

drylin® E – configure and order individually

## “Search”

drylin® product finder for linear slide tables  
Just enter useful application-data and compare adequate Linear Slide Tables online and then configure.

► [www.igus.eu/sht-productfinder](http://www.igus.eu/sht-productfinder)



## “Configure”

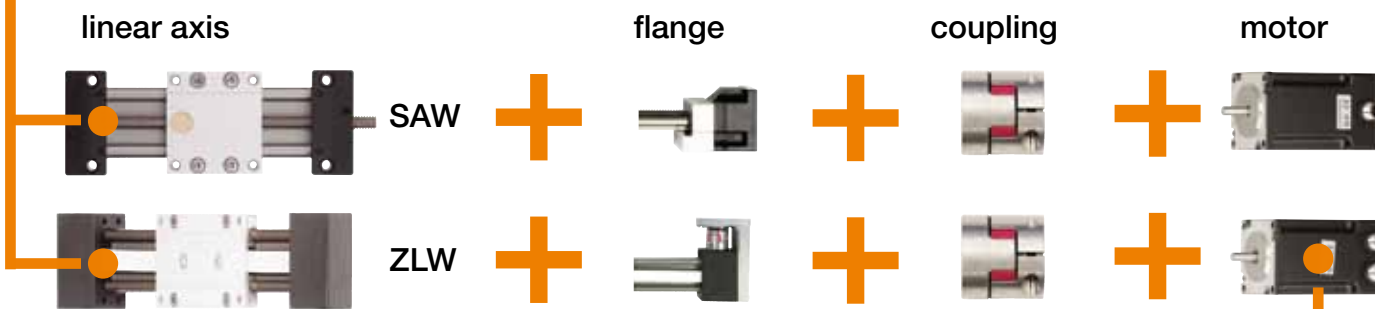

## “Ready”

Linear actuators with motor

- Lightweight
- Cost-effective
- 100% lubrication-free
- More than 50 versions available from stock in 3-4 days

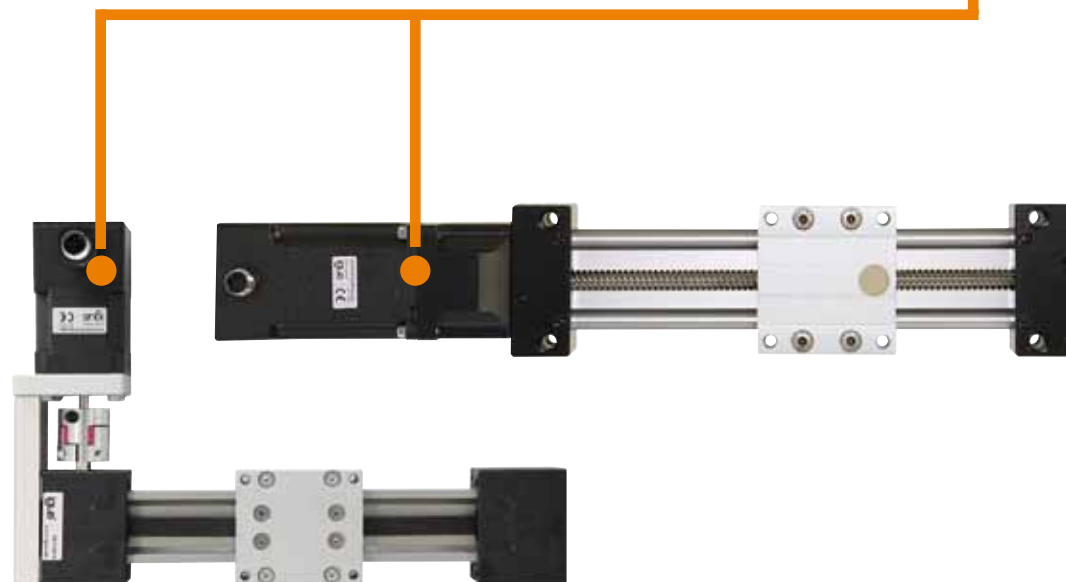

# ...find online...

calculate, compare and select the right drive units

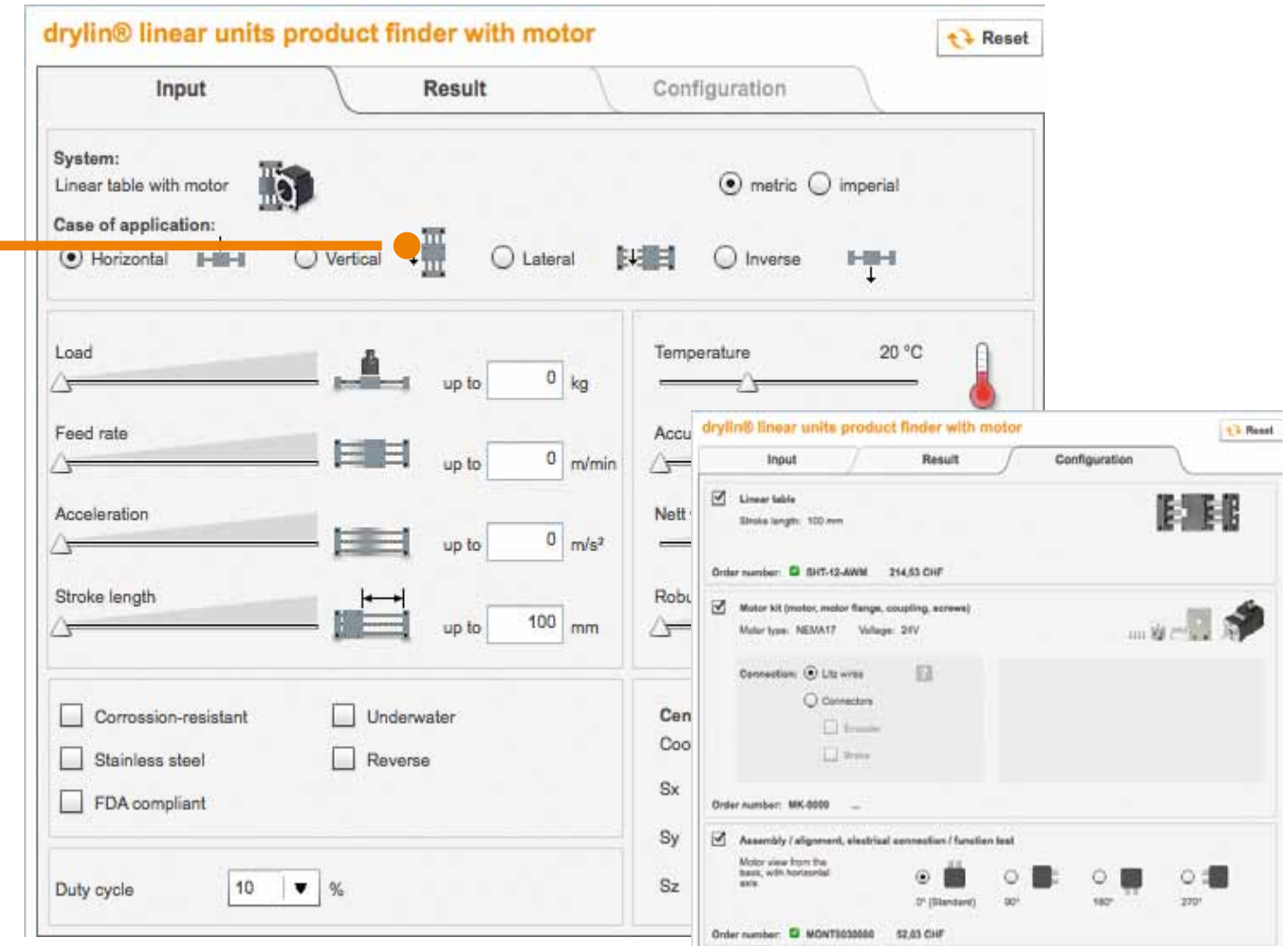

In addition to calculating the correct linear unit, the product finder for drylin® drive technology also provides for the option to calculate the correct motors, incl. service life. The identified solutions can be directly configured and ordered using the same tool.

- Linear solutions tailored to your application, incl. motor if desired
- Configurable accessories and order function
- When selecting motor incl. load calculation
- Easy to understand results screen to select the ideal solution
- Convenient access to other functions, such as online catalog, shopping cart, downloads, etc.

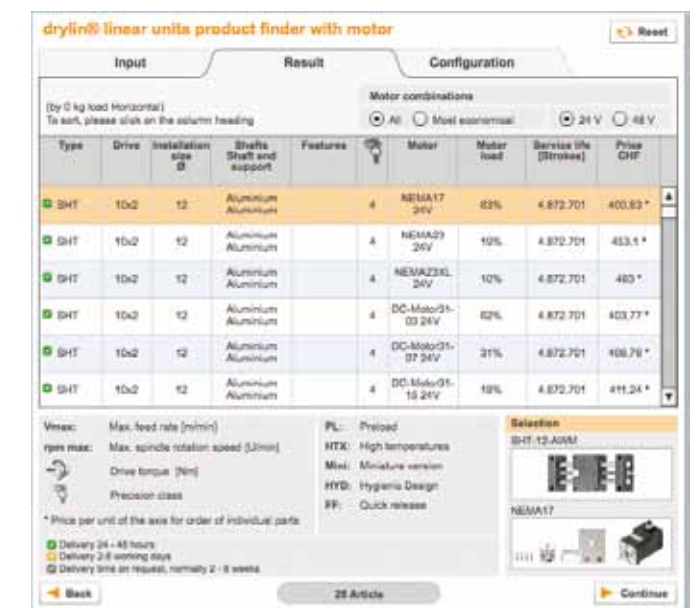

[www.igus.eu/eu/drylinE-finder](http://www.igus.eu/eu/drylinE-finder)

# ...Linear axes with motor...SAW...

## Linear axes with lead screw drive



### + When to use it?

- For format adjustments and to position medium loads
- In extreme environments
- When a cost-effective, ready-to-install solution is needed
- When it should be low noise
- For unsupported installations

### - When not to use it?

- When high loads need to travel at highly dynamic forces
- When positioning accuracy < 0.1 mm is required
- When high running performance is required in continuous operation

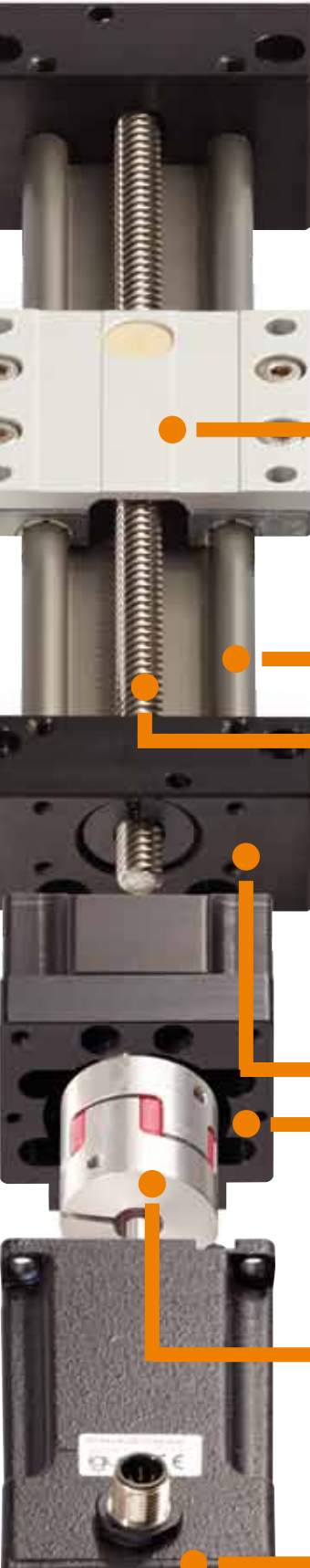

Lubricant and maintenance-free drylin® W linear guide systems

Hard anodized drylin® W aluminum profile (high profile shape)

4 trapezoidal thread pitches  
3 high helix thread pitches

Shaft end support from aluminum or plastics

Motor flange:  
motor connections

Claw coupling

- |   |   |
|---|---|
| <p>igus® DC motors</p> <ul style="list-style-type: none"> <li>● Cost-effective</li> <li>● Maintenance-free</li> <li>● 4 versions</li> <li>● Battery operation possible</li> </ul> | <p>igus® stepper motors</p> <ul style="list-style-type: none"> <li>● Cost-effective</li> <li>● Maintenance-free</li> <li>● 5 installation sizes</li> <li>● 17 versions</li> </ul> |
|---|---|



### Order key

**SAW-1040-EPL-07-S0020RG-450-17-M-S-000**

#### Type

#### Installation size

- 0630
- 1040
- 1660

#### Design

##### SAW-0630

- S: Standard
- M: Mono carriage (plastic)

##### SAW-1040/1660

- S: Standard
- E: Adjustable linear bearing
- PL: Pretensioned (50N)
- EPL: Adjustable, pretensioned (50 N)

#### Carriage length

##### SAW-0630

- 06: 60 mm (Standard)

##### SAW-1040

- 07: 69 mm (Standard)
- 10: 100 mm
- 15: 150 mm

##### SAW-1660

- 15: 150 mm (Standard)

#### Lead screw material:

- S: steel
- E: stainless steel

#### Lead screw pitch

##### SAW-0630

- 0015: TR8x1,5 mm (steel)
- 0150: SG8x15 mm (stainless steel)

##### SAW-1040

- 0020: TR10x2 mm (steel/stainless steel)
- 0030: TR10x3 mm (steel/stainless steel)
- 0120: SG10x12 mm (stainless steel)
- 0500: SG10x50 mm (stainless steel)

##### SAW-1660

- 0040: TR14x4 mm (steel/stainless steel)

#### Electrical connection alignment

- 000: 0° (Standard)
- 090: 90°
- 180: 180°
- 270: 270°

#### Assembly

- S: Assembly on the drive pin (standard)

#### Motor option

- L: Litz wires
- M: Metric connectors
- C: Encoders
- D: Encoder and brake
- F: Low profile connector (DC-Motor)

#### Motor size

- 17: NEMA17: recommended axis 0630
- 23: NEMA23: recommended axis 1040
- 23XL: NEMA23XL: recommended axis 1040
- DC01: DC-Motor: 0,1 Nm recommended axis 0630
- DC03: DC-Motor: 0,3 Nm recommended axis 0630/1040
- DC07: DC-Motor: 0,7 Nm recommended axis 0630
- DC15: DC-Motor: 1,5 Nm recommended axis 1040/1660

#### Stroke length

- SAW-0630: max. 300 mm
- SAW-1040: max. 500 mm
- SAW-1660: max. 750 mm

#### Lead screw end

- G: Threaded end

#### Thread

- R: Right | L: Left



[www.igus.eu/eu/drylinSAW](http://www.igus.eu/eu/drylinSAW)

# ...Linear axes with motor...SLW...

## Linear axes with lead screw drive

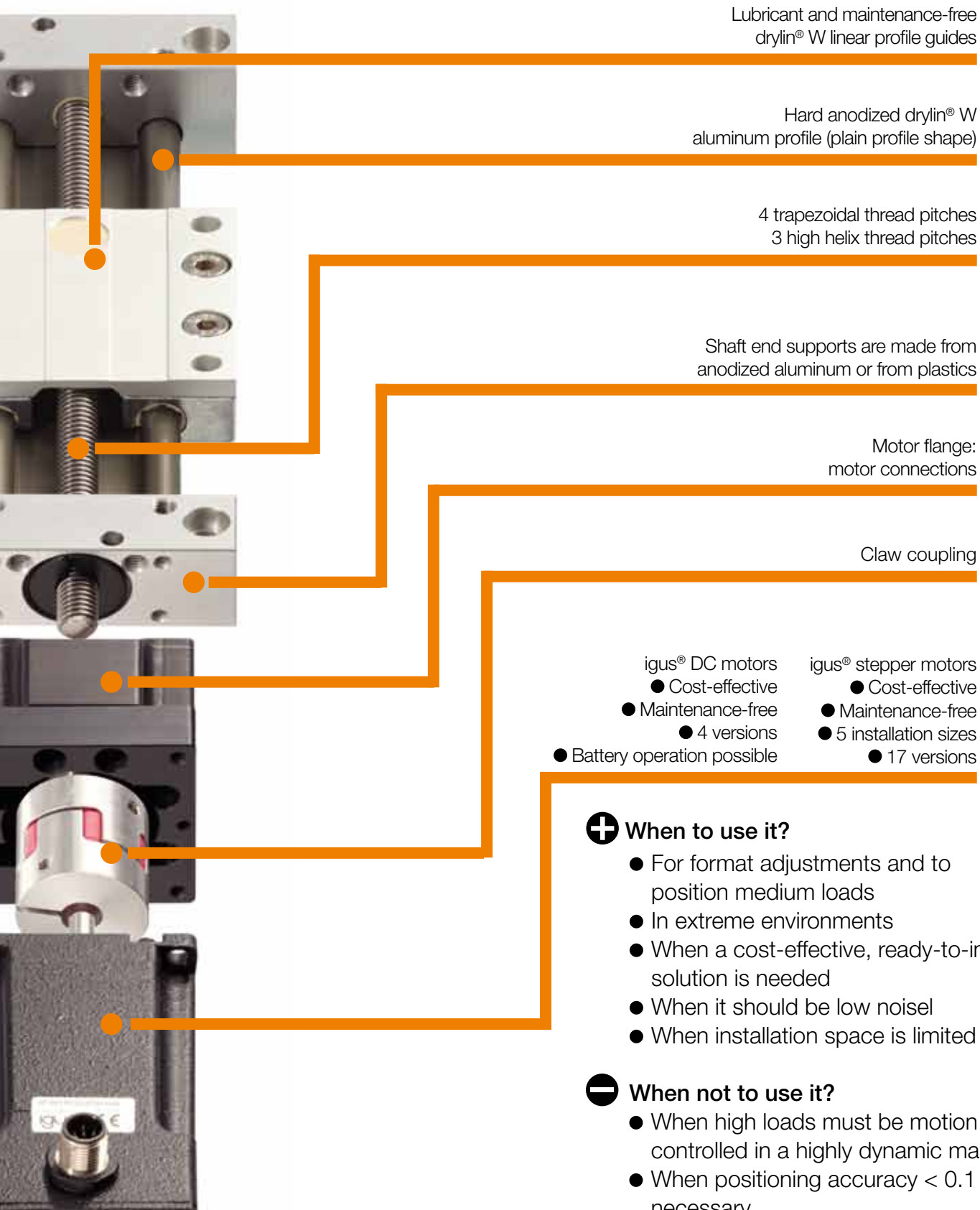

Lubricant and maintenance-free drylin® W linear profile guides

Hard anodized drylin® W aluminum profile (plain profile shape)

4 trapezoidal thread pitches  
3 high helix thread pitches

Shaft end supports are made from anodized aluminum or from plastics

Motor flange: motor connections

Claw coupling

- |   |   |
|---|---|
| <p>igus® DC motors</p> <ul style="list-style-type: none"> <li>● Cost-effective</li> <li>● Maintenance-free</li> <li>● 4 versions</li> <li>● Battery operation possible</li> </ul> | <p>igus® stepper motors</p> <ul style="list-style-type: none"> <li>● Cost-effective</li> <li>● Maintenance-free</li> <li>● 5 installation sizes</li> <li>● 17 versions</li> </ul> |
|---|---|

- +** When to use it?
- For format adjustments and to position medium loads
  - In extreme environments
  - When a cost-effective, ready-to-install solution is needed
  - When it should be low noise
  - When installation space is limited
- When not to use it?
- When high loads must be motion controlled in a highly dynamic manner
  - When positioning accuracy < 0.1 mm is necessary
  - When high running performance is required in continuous operation



### Order key

**SLW-1040-EPL-07-S0020 R G-750-17-L-S-000**

### Type

### Installation size

- 0630
- 1040/1080
- 1660
- 2080

### Design

- SLW-0630**
- BB:** Ball bearing
- SLW-1040/1080/1660/2080**
- S:** Standard
  - E:** Adjustable linear bearing
  - PL:** Pretensioned (50N)
  - EPL:** Adjustable, pretensioned (50 N)
  - BB:** Ball bearing
  - BBE:** Ball bearing, Adjustable linear bearing
  - BBPL:** Ball bearing, pretensioned (50 N)
  - BBEPL:** Ball bearing, Adjustable linear bearing, pretensioned (50N)

### Carriage length

- SLW-0630**
- 06:** 60 mm (Standard)
- SLW-1040**
- 07:** 69 mm (Standard)
  - 10:** 100 mm
  - 15:** 150 mm
- SLW-1080/1660/2080**
- 15:** 150 mm (Standard)

### Lead screw material

- S:** steel
- E:** stainless steel

### Lead screw pitch

- SLW-0630**
- 0015:** TR8x1,5 mm (steel)
  - 0150:** SG8x15 mm (stainless steel)
- SLW-1040/1080**
- 0020:** TR10x2 mm (steel/stainless steel)
  - 0030:** TR10x3 mm (steel/stainless steel)
  - 0120:** SG10x12 mm (stainless steel)
  - 0500:** SG10x50 mm (stainless steel)
- SLW-1660**
- 0040:** TR14x4 mm (steel/stainless steel)
- SLW-2080**
- 0040:** TR18x4 mm (steel/stainless steel)

### Electrical connection alignment

- 000:** 0° (Standard)
- 090:** 90°
- 180:** 180°
- 270:** 270°

### Assembly

- S:** Assembly on the drive pin (standard)

### Motor option

- L:** Litz wires
- M:** Metric connectors
- C:** Encoders
- D:** Encoder and brake
- F:** Low profile connector (DC motor)

### Motor size/Recommended axis

- 17:** NEMA17 / 0630
- 23:** NEMA23 / 1040, 1080
- 23XL:** NEMA23XL / 1040, 1080, 1660
- 34:** NEMA 34 / 2080
- DC01:** DC-Motor: 0,1 Nm / 0630
- DC03:** DC-Motor: 0,3 Nm / 0630, 1040
- DC07:** DC-Motor: 0,7 Nm / 1040
- DC15:** DC-Motor: 1,5 Nm / 1040, 1660

### Stroke length

- SLW-0630:** max. 300 mm
- SLW-1040/1080:** max. 750 mm (BB: max.500 mm)
- SLW-1660:** max 750 mm
- SLW-2080:** max 1000 mm (BB: 900 mm)

### Lead screw end

- G:** Threaded end
- Z:** End 12h9 (with SLW-2080)

### Thread

- R:** Right | **L:** Left





# ...Linear axes with motor...SHT...

## Linear axes with lead screw drive



3 shaft materials

4 trapezoidal thread pitches  
3 high helix thread pitches

Lubricant and maintenance-free with drylin® liners and lead screw nuts

Carriages and shaft end supports from anodized aluminum

Motor flange: motor connections

Claw coupling

- |   |   |
|---|---|
| <ul style="list-style-type: none"> <li>● igus® DC motors</li> <li>● Cost-effective</li> <li>● Maintenance-free</li> <li>● 4 versions</li> <li>● Battery operation possible</li> </ul> | <ul style="list-style-type: none"> <li>● igus® stepper motors</li> <li>● Cost-effective</li> <li>● Maintenance-free</li> <li>● 5 installation sizes</li> <li>● 17 versions</li> </ul> |
|---|---|

- +** **When to use it?**
- For format adjustments and for positioning medium loads
  - In extreme environments
  - When a cost-effective, ready-to-install solution is needed
  - When it should be low noise
  - With low profile installation space
- **When not to use it?**
- When high loads must be motion controlled in a highly dynamic manner
  - When positioning accuracy < 0.1 mm is necessary
  - If high running performance is required in continuous operation



### Order key

**SHT-12-BBZB-AWM-S0020RG-750-17-L-S-000**

<p><b>Type</b></p>	<p><b>Electrical connection alignment</b> 000: 0° (Standard) 090: 90° 180: 180° 270: 270°</p>
<p><b>Installation size</b> 12 20 30</p>	<p><b>Assembly</b> <b>S:</b> Assembly on the drive pin (standard)</p>
<p><b>Design</b> <b>S:</b> Standard <b>PL:</b> Pretensioned (50 N) <b>BB:</b> Ball bearing <b>BBPL:</b> Ball bearing, pretens. (50 N) <b>BBZB:</b> Ball bearing, Zero-Backlash (only SHT-12 with SG10x12)</p>	<p><b>Motor option</b> <b>L:</b> Litz wires <b>M:</b> Metric connectors <b>C:</b> Encoders <b>D:</b> Encoder and brake <b>F:</b> Low profile connector (DC motor)</p>
<p><b>Shaft material</b> <b>AWM:</b> Hard-anodized aluminum <b>SWM:</b> Cf53 (1.1213) <b>EWM:</b> stainless steel X105 (1.4125)</p>	<p><b>Motor size</b> <b>17:</b> NEMA17: recommended axis 12 <b>23:</b> NEMA23: recommended axis 12/20 <b>23XL:</b> NEMA23XL: recommended axis 20 <b>34:</b> NEMA34: recommended axis 20/30 <b>DC01:</b> DC-Motor: 0,1 Nm recommended axis 12 <b>DC03:</b> DC-Motor: 0,3 Nm recommended axis 12 <b>DC07:</b> DC-Motor: 0,7 Nm recommended axis 12 <b>DC15:</b> DC-Motor: 1,5 Nm recommended axis 12</p>
<p><b>Lead screw material</b> <b>S:</b> steel <b>E:</b> stainless steel</p>	<p><b>Stroke length</b> <b>SHT-12:</b> max. 750 mm (BB max. 500 mm) <b>SHT-20:</b> max. 1000 mm (BB max. 900 mm) <b>SHT-30:</b> max 1250 mm (BB max. 1000 mm)</p>
<p><b>Lead screw pitch</b> <b>SHT-12</b> 0020: T10x2 mm (steel/stainless steel) 0030: TR10x3 mm (steel/stainless steel) 0120: SG10x12 mm (stainless steel) 0500: SG10x50 mm (stainless steel) <b>SHT-20</b> 0040: TR18x4 mm (steel/stainless steel) <b>SHT-30</b> 0050: TR24x5 mm (steel/stainless steel)</p>	
<p><b>Thread</b> <b>R:</b> Right   <b>L:</b> Left</p>	
<p><b>Lead screw end</b> <b>G:</b> Threaded end (with SHT-12) <b>Z:</b> End 12h9 (with SHT-20) <b>Z:</b> End 14h9 (with SHT-30)</p>	





# ...Linear axes with motor...ZLW...

## Linear axes with toothed belt

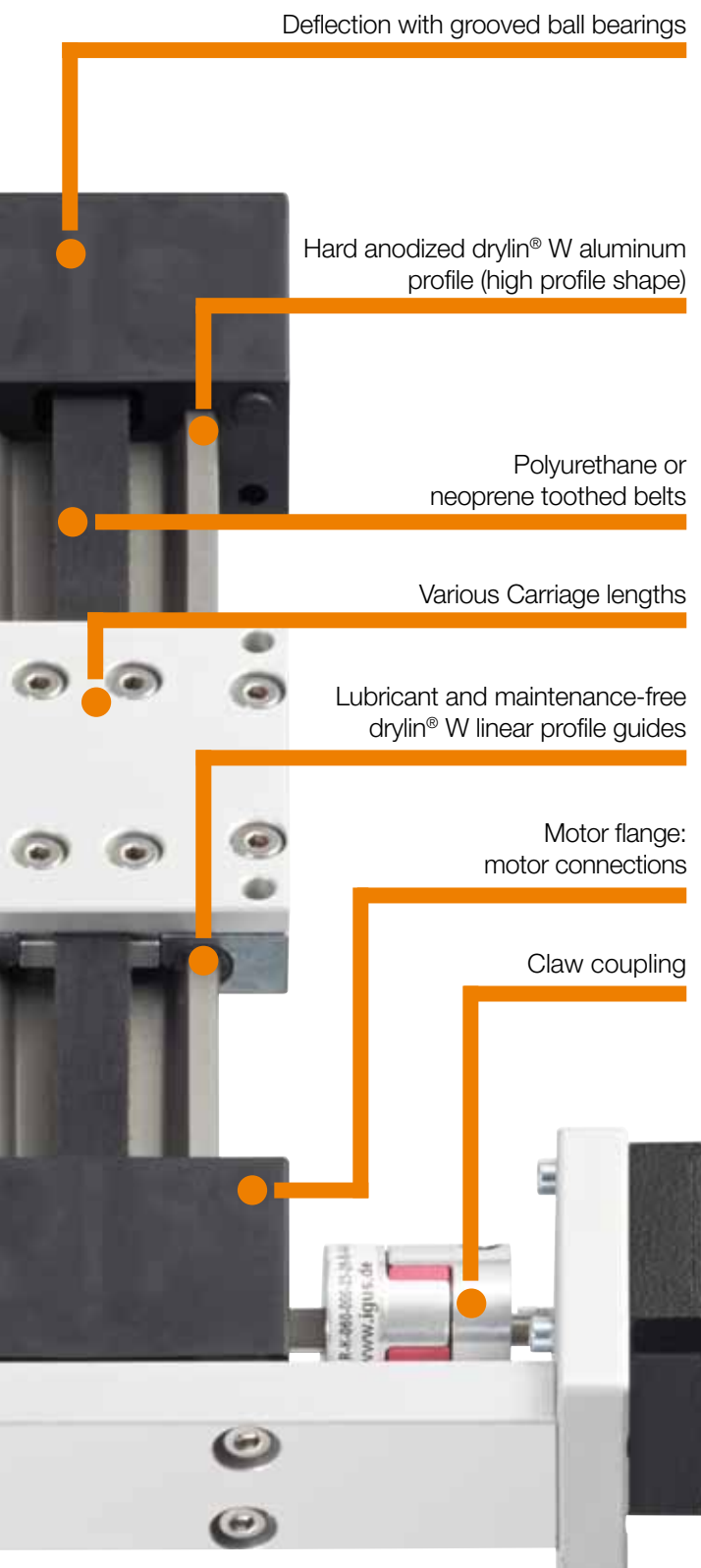

- +** When to use it?
- Quick positioning of small loads
  - Quiet operation
  - Slim structure
  - Continuous operation
- When not to use it?
- When high loads must be motion controlled in a highly dynamic manner
  - When positioning accuracy < 0.1 mm is necessary

- igus® stepper motors
- Cost-effective
  - Maintenance-free
  - 5 installation sizes
  - 17 versions

- igus® DC motors
- Cost-effective
  - Maintenance-free
  - 4 versions
  - Battery operation possible



### Order key

**ZLW-1040-02-B-60-L-750-17-M-S-000**

Type  
ZLW

Installation size  
0630  
1040  
1660

Version  
02: With grooved ball bearings

Design  
S: Type series - standard  
B: Type series - basic

Carriage length  
60: 60 mm (only ZLW 0630)  
100: 100 mm  
150: 150 mm  
200: 200 mm  
250: 250 mm

Drive pins  
L: Left-hand drive pin  
R: Right-hand drive pin  
L/R: Drive both sides

Stroke length  
ZLW-0630: max. 1.000 mm  
ZLW-1040: max. 2.000 mm  
ZLW-1660: max. 3.000 mm

### Electrical connection alignment

000: 0° (Standard)  
090: 90°  
180: 180°  
270: 270°

### Assembly

S: Assembly with one drive pin (standard)

### Motor option

L: Litz wires  
M: Metric connectors  
C: Encoders  
D: Encoder and brake  
F: Low profile connector (DC motor)

### Motor size

17: NEMA17: recommended axis 0630  
23: NEMA23: recommended axis 1040  
23XL: NEMA23XL: recommended axis 1040  
34: NEMA34: recomm. axis 1040/1660  
DC01: DC-Motor 0,1 Nm: recommended axis 0630  
DC03: DC-Motor: 0,3 Nm: recommended axis 0630  
DC07: DC-Motor: 0,7 Nm recommended axis 1040  
DC15: DC-Motor: 1,5 Nm recommended axis 1040



# Linear axes with motor...SLN&GRW.

## Miniature linear axis with lead screw drive



Base body made from corrosion resistant rugged plastic

Lubricant-free linear guide using polymer plain bearings

Lubricant and maintenance-free drylin® N low profile linear guides

1 trapezoidal thread pitch, 1 high helix thread pitch

Motor flange: motor connections

- igus® stepper motors
- Cost-effective
  - Maintenance-free
  - 1 installation size
  - 2 versions

## Cantilever axis with rack drive

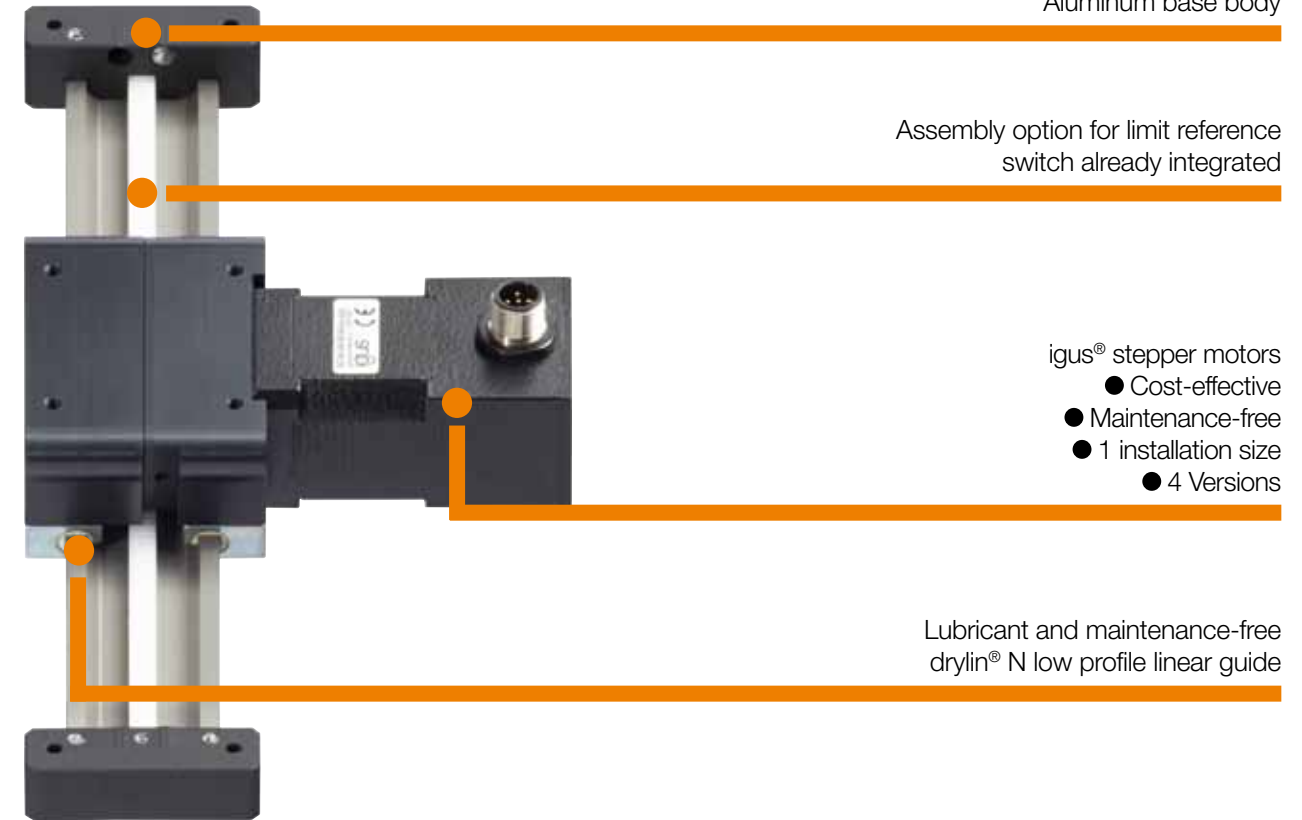
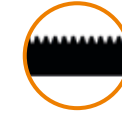

Aluminum base body

Assembly option for limit reference switch already integrated

- igus® stepper motors
- Cost-effective
  - Maintenance-free
  - 1 installation size
  - 4 Versions

Lubricant and maintenance-free drylin® N low profile linear guide



### Order key

**SLN-27-02-0050-100-11-L-S-000**

Type	SLN	Motor pin alignment	000: 0° (Standard) 090: 90° 180: 180° 270: 270°
Installation size	27	Assembly	S: Assembly with one drive pin (standard)
Design	02: With motor	Motor option	L: Litz wires C: Encoders
Lead screw pitch	SLN-27: 0008: M5x0,8 mm (stainless steel) 0050: SG5x5 mm (stainless steel)	Motor size	11: NEMA11
		Stroke length	SLN-27: max. 250 mm



### Order key:

**GRW-0630-A-80-150-17-L-S-000**

Type	GRW	Motor pin alignment	000: 0° (Standard) 090: 90° 180: 180° 270: 270°
Installation size	0630	Assembly	S: Assembly with one drive pin (standard)
Design	A: Standard	Motor option	L: Litz wires M: Metric connectors C: Encoders D: Encoder and brake
Carriage length	80: 80 mm	Motor size	17: NEMA17
Hublänge	GRW-0630: max. 150 mm		





# igus<sup>®</sup>.eu/20h

Ordering and deliveries weekdays from 7.00 am to 8.00 pm, Saturday from 8.00 am to 12.00 pm. No minimum order quantities, no surcharges.

Quick delivery.

[www.igus.eu](http://www.igus.eu) Tel. +49-2203 9649-0 Fax -222

# igus<sup>®</sup>.eu/24

Online shopping – 24 h!

More catalogs and brochures online – [www.igus.eu/downloads](http://www.igus.eu/downloads)

# ISO 9001:2008

# ISO/TS 16949:2009

In the sector of energy chains<sup>®\*</sup> with cables and assembly as well as plastic plain bearings, igus<sup>®</sup> is certified according to DIN EN ISO 9001 : 2008 and ISO/TS 16949 : 2009\*.

# igus<sup>®</sup>.eu/ready

Ask for fully harnessed and preassembled readychains<sup>®</sup> –

increase your cash-flow and profit immediately – [www.readychain.eu](http://www.readychain.eu)

# igus<sup>®</sup>.eu

igus<sup>®</sup> GmbH Spicher Straße 1a D-51147 Cologne  
Phone +49 22 03/96 49-145 Fax +49 22 03/96 49-334  
[info@igus.de](mailto:info@igus.de) [www.igus.eu](http://www.igus.eu) [www.drylin.eu](http://www.drylin.eu)

MAT0071843.20 Stand 05/2013  
Subject to technical alterations